

# Vector Frame Monitor Kiosk 02

VF-MK-02-SS  
VF-MK-02-DS

Vector Frame™ monitor kiosks are a sleek, stylish way to display media at any trade show, event, in a retail or corporate space. These new kiosks feature push-fit fabric graphics, easy-to-assemble 100mm extrusion frames and your choice of one or two monitor mounts (monitors not included). These kiosks compliment the Vector Frame line of banners, back-wall, exhibit kits and counters.

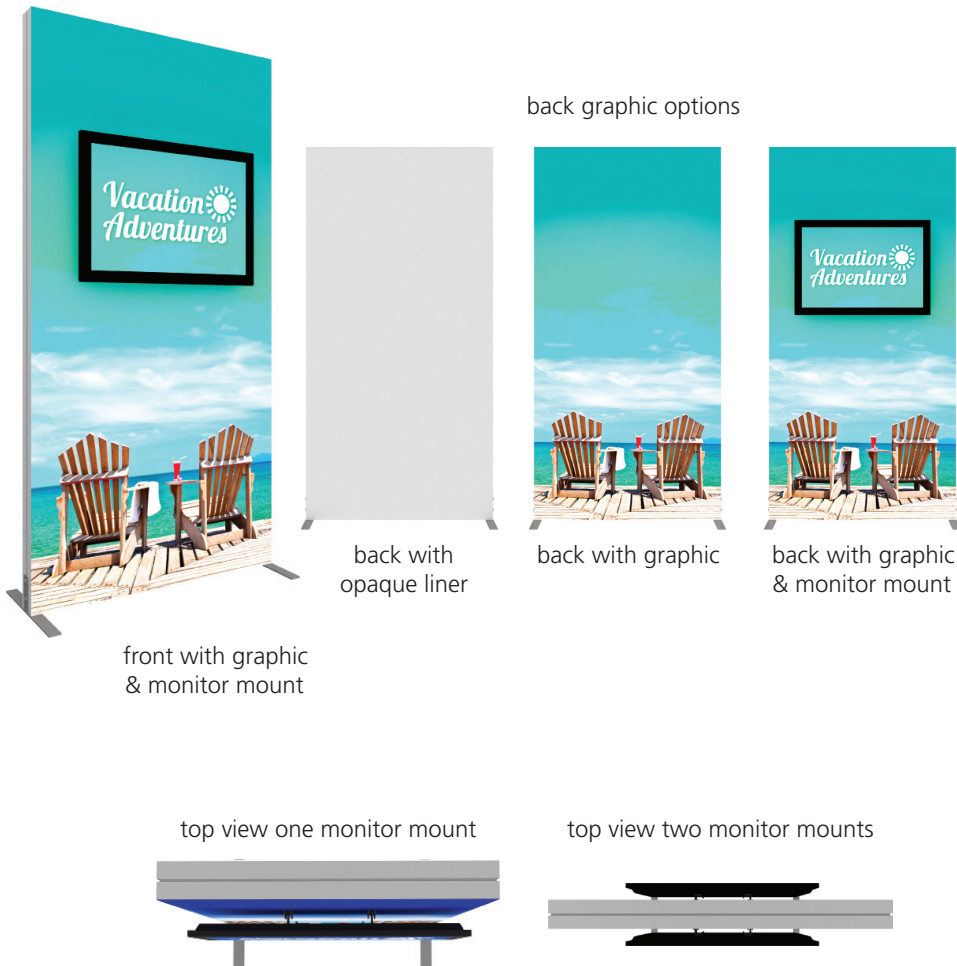

## features and benefits

- 100mm silver extrusion frame
- Single or double-sided SEG dye-sublimated fabric graphics
- Kiosk supports 26-40" monitor\*; max weight = 25 lbs each
- Comes packaged in one OCH wheeled molded case for transport or storage
- Lifetime hardware warranty against manufacturer defects

## dimensions

Hardware	Graphic
<p>Assembled unit: 48.11" w x 94.74" h x 19.685" d 1221.994mm(w) x 2406.396mm(h) x 499.999mm(d)</p>	<p>Refer to related graphic templates for more information</p> <p>Visit: <a href="http://www.exhibitors-handbook.com/graphic-templates/">www.exhibitors-handbook.com/graphic-templates/</a></p>
<p>Shipping</p> <p>Shipping dimensions - ships in 1 case: 1 OCH case: 50" l x 26" h x 12" d 1270mm(l) x 660mm(h) x 305mm(d)</p> <p>Approximate shipping weight (with case): VF-MK-02-SS: 84.17 lbs / 38.2 kgs VF-MK-02-DS: 98.67 lbs / 44.75 kgs</p>	

## additional information

Graphic material:  
Dye-sublimated fabric

\*monitor(s) not included

- Monitor 26-40"; max weight = 25 lbs

We are continually improving and modifying our product range and reserve the right to vary the specifications without prior notice. All dimensions and weights quoted are approximate and we accept no responsibility for variance. E&OE. See Graphic Templates for graphic bleed specifications.

Parts Included VF-MK-02-SS:

Code	Qty	Description
F25	x2	1200MM (47.25") LENGTH OF PHFC4 EXTRUSION - WITH MITRE CUT FOR CB9 BOTH SIDES
F27	x3	1200MM (47.25") LENGTH OF PHFC4 EXTRUSION - WITH MITRE CUT FOR CB9 ONE END - IB2 LOCK HOLES ONE END
F60	x1	1200MM (47.25") LENGTH OF PHFC4 EXTRUSION - WITH MITRE CUT FOR CB9 ONE END - IB2 LOCK HOLES ONE END WITH WIRE CHASE HOLE
VE-95	x1	1200MM LENGTH OF PS2 EXTRUSION CUT DOWN TO 873MM WITH LOCKS ON BOTH ENDS (INSIDE)
VF-MK-02-CC-G	x1	900MM (35.43")W X 2400MM (94.5")H FABRIC GRAPHIC W/FEC-2 ALL SIDES
VF-MK-02-OP-LN	x1	900MM (35.43")W X 2400MM (94.5")H OPAQUE LINER W/FEC-2 ALL SIDES
CB9	x4	CB9 CORNER BRACKET
SW-FOOT	x2	VECTOR FRAME SUPPORT FOOT
IB2	x2	PH INLINE CONNECTOR
WME-1000	x1	1000MM (39.37") GREY RPVC WIRE MANAGEMENT EXTRUSION
LN-LCD2-B	x1	MEDIUM MONITOR BRACKET

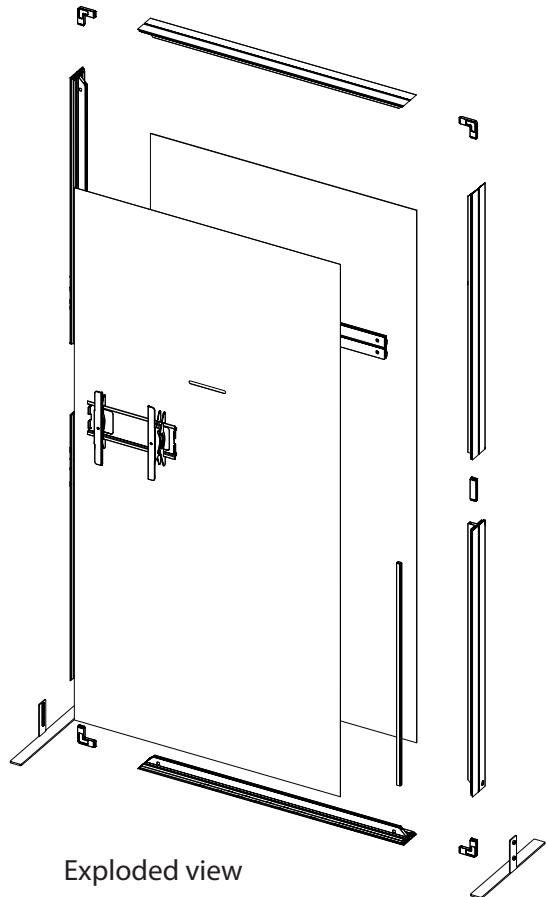

Exploded view

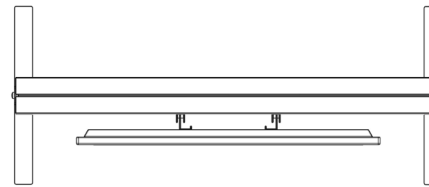

Overhead view

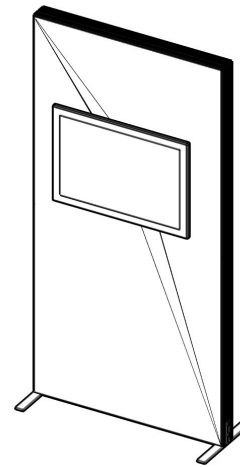

Assembled view

Parts Included VF-MK-02-SS-GDBL:

Code	Qty	Description
F25	x2	1200MM (47.25") LENGTH OF PHFC4 EXTRUSION - WITH MITRE CUT FOR CB9 BOTH SIDES
F27	x3	1200MM (47.25") LENGTH OF PHFC4 EXTRUSION - WITH MITRE CUT FOR CB9 ONE END - IB2 LOCK HOLES ONE END
F60	x1	1200MM (47.25") LENGTH OF PHFC4 EXTRUSION - WITH MITRE CUT FOR CB9 ONE END - IB2 LOCK HOLES ONE END WITH WIRE CHASE HOLE
VE-95	x1	1200MM LENGTH OF PS2 EXTRUSION CUT DOWN TO 873MM WITH LOCKS ON BOTH ENDS (INSIDE)
VF-MK-02-CC-G	x1	900MM (35.43")W X 2400MM (94.5")H FABRIC GRAPHIC W/FEC-2 ALL SIDES
VF-MK-02-NC-G	x1	900MM (35.43")W X 2400MM (94.5")H OPAQUE LINER W/FEC-2 ALL SIDES
CB9	x4	CB9 CORNER BRACKET
SW-FOOT	x2	VECTOR FRAME SUPPORT FOOT
IB2	x2	PH INLINE CONNECTOR
WME-1000	x1	1000MM (39.37") GREY RPVC WIRE MANAGEMENT EXTRUSION
LN-LCD2-B	x1	MEDIUM MONITOR BRACKET

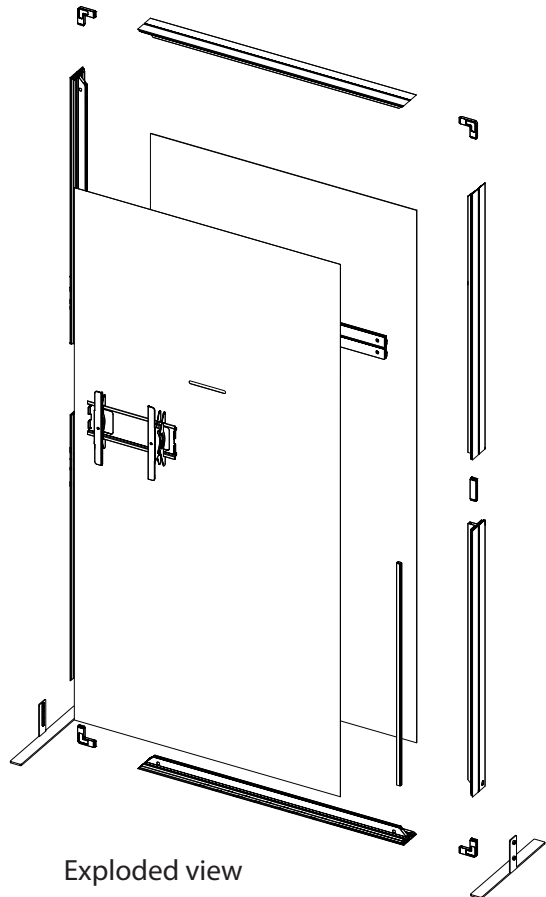

Exploded view

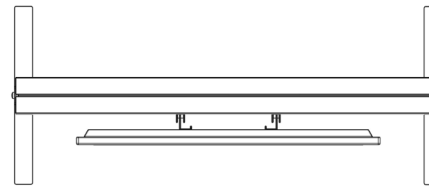

Overhead view

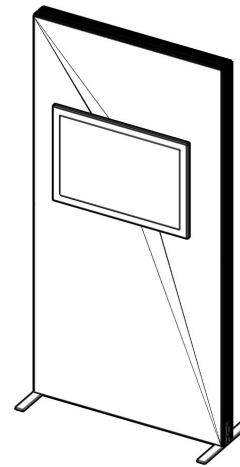

Assembled view

## Single Sided Step 1: Assemble Frame

Arrange pieces on the floor as shown in the diagram below. Assemble frame by locking F25s to F27s and F60. When locking be sure to turn each cam a little bit and then go back and tighten to the proper tension. Take care to turn locks only half a turn. Slide two bolts for monitor mount into channel of VE-95 and lock to extrusion at proper height.

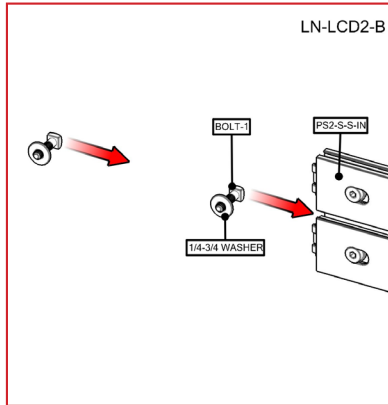
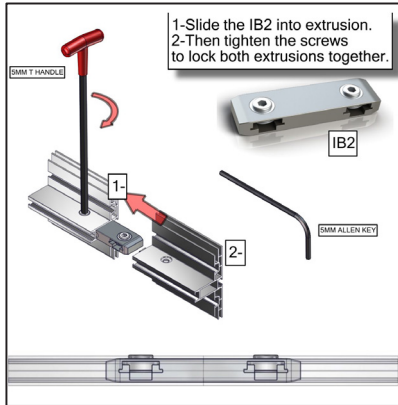

**\*Very Important!**  
Insert set of monitor bolts into VE-95 channel before securing extrusion to F27

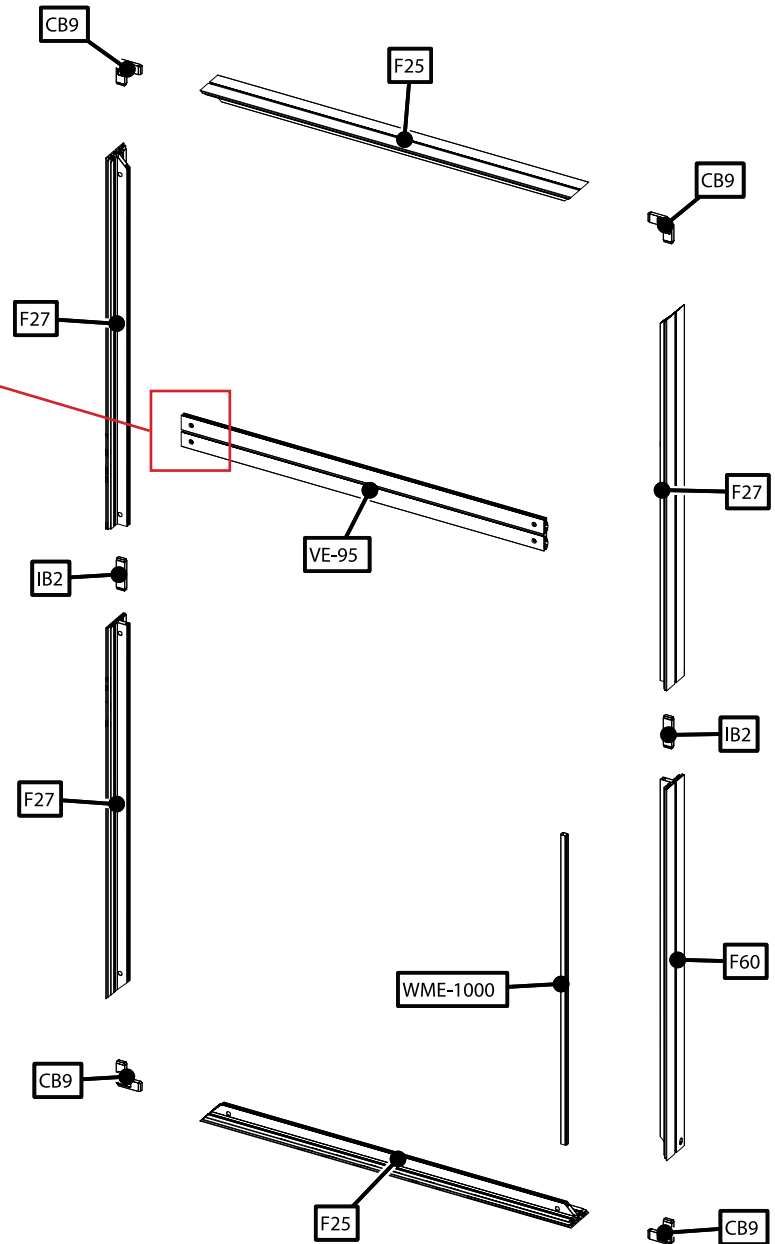
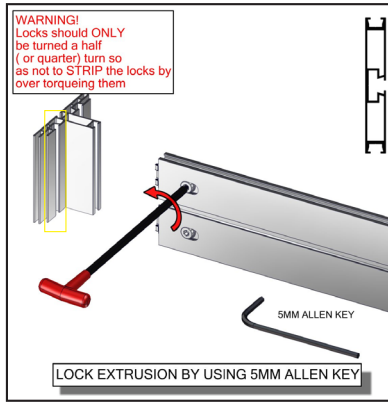
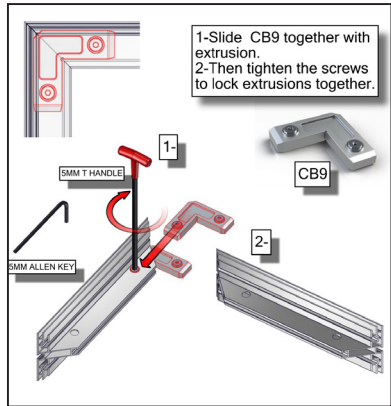

## Single Sided Step 2: Attach feet to frame & apply graphics

To adhere foot to frame, loosen thumbscrews from foot. Slide extrusion into LN-100 groove. Gently tighten the foot into place. Install graphics by pressing the FCE-2 edge of graphic into the channel of the extrusion. Depending on options for back side, graphic will either be opaque or printed fabric. Make sure slit in printed fabric for monitor mount is near top of frame. Start in upper left corner, go across the top and then down the sides to the bottom. Assure each graphic is tightly inserted. When taking graphics off, take care to gently pull by attached pull tab.

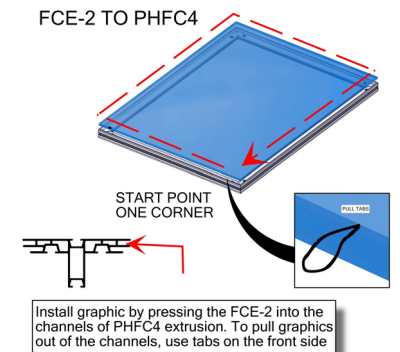
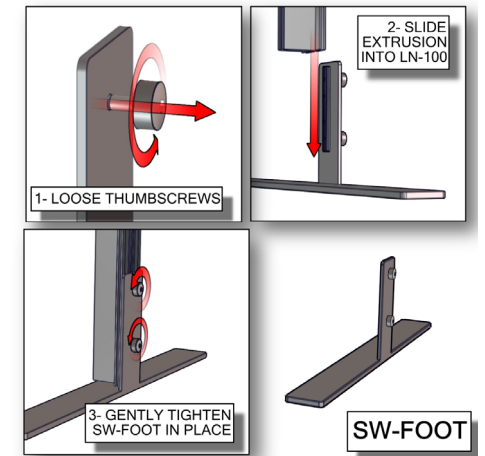
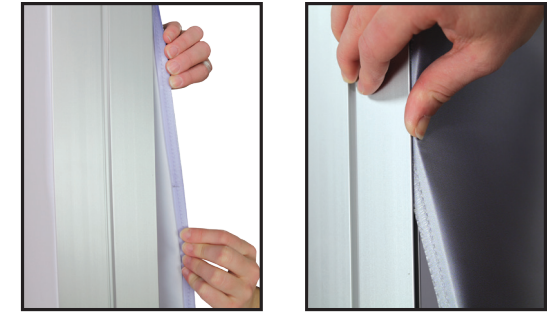
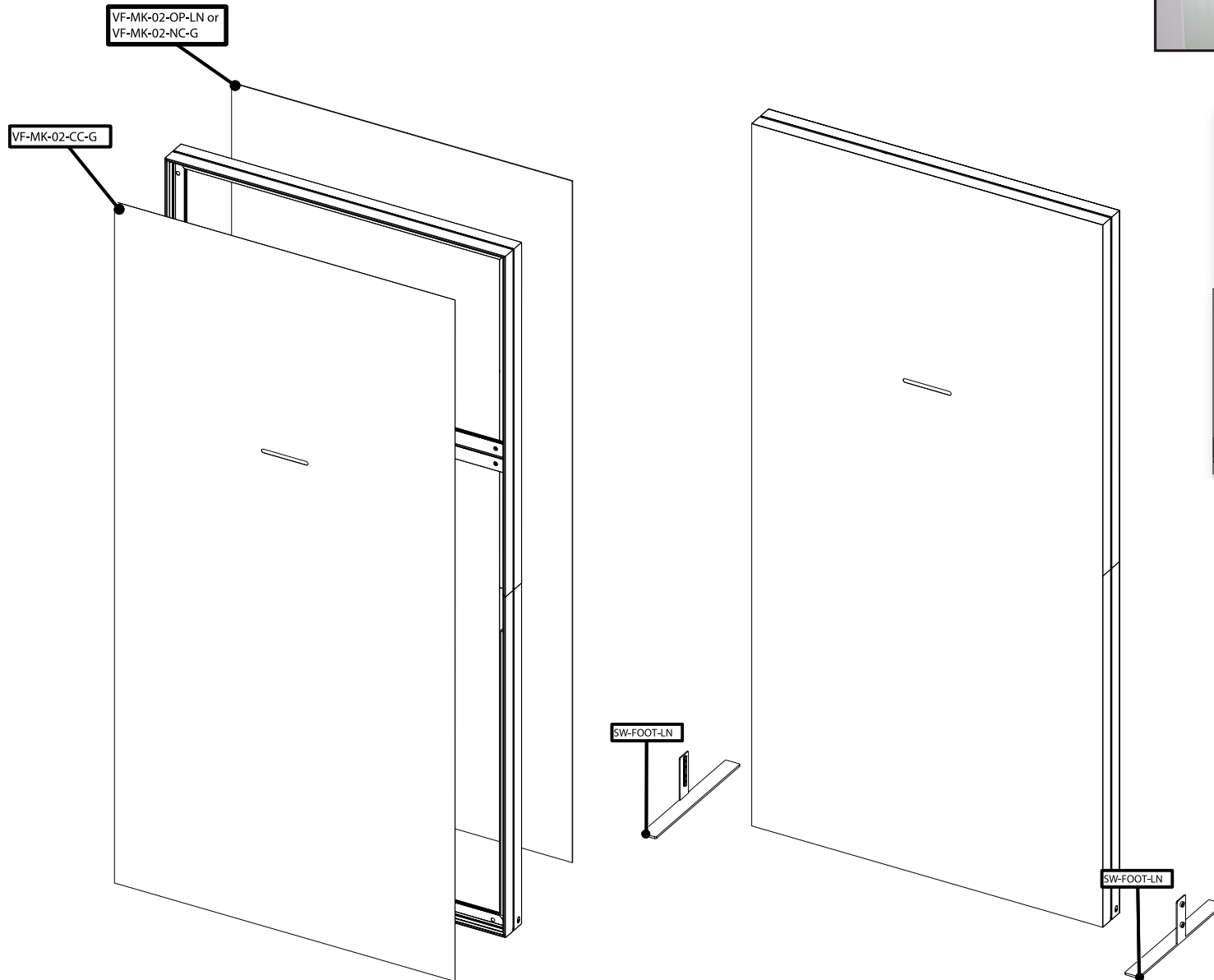

### Single Sided Step 3: Monitor Mount & Wire Management

Attach monitor mount to bolts in VE-95 at graphic slit. Insert monitor cord into plastic wire management strip and snap on to extrusion channel. Run through hole in frame and connect to power supply.

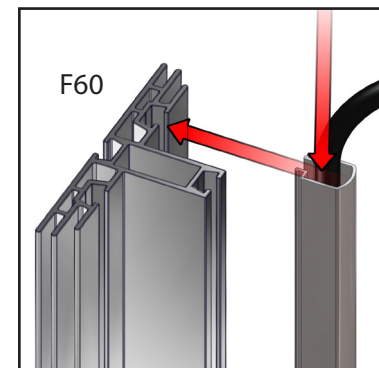
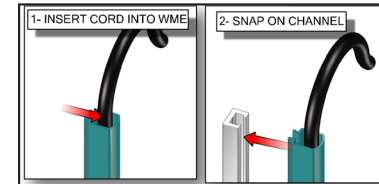
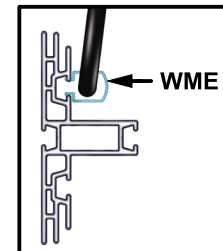
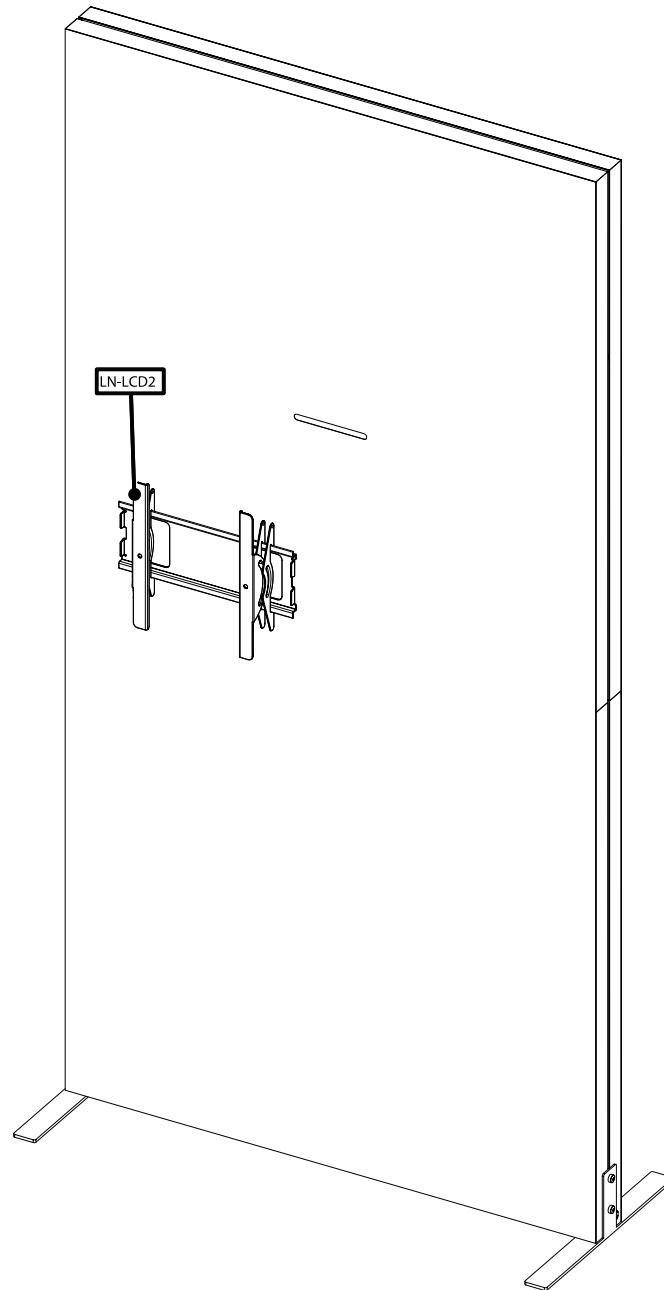
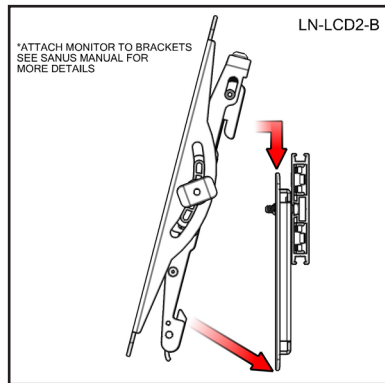
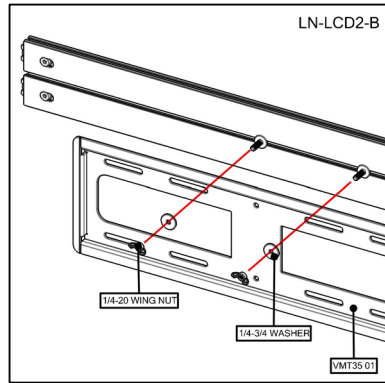

Parts Included VF-MK-02-DS-GDBL:

Code	Qty	Description
F25	x2	1200MM (47.25") LENGTH OF PHFC4 EXTRUSION - WITH MITRE CUT FOR CB9 BOTH SIDES
F27	x3	1200MM (47.25") LENGTH OF PHFC4 EXTRUSION - WITH MITRE CUT FOR CB9 ONE END - IB2 LOCK HOLES ONE END
F60	x1	1200MM (47.25") LENGTH OF PHFC4 EXTRUSION - WITH MITRE CUT FOR CB9 ONE END - IB2 LOCK HOLES ONE END WITH WIRE CHASE HOLE
VE-95	x2	1200MM LENGTH OF PS2 EXTRUSION CUT DOWN TO 873MM WITH LOCKS ON BOTH ENDS (INSIDE)
VF-MK-02-CC-G	x2	900MM (35.43")W X 2400MM (94.5")H FABRIC GRAPHIC W/FEC-2 ALL SIDES
CB9	x4	CB9 CORNER BRACKET
SW-FOOT	x2	VECTOR FRAME SUPPORT FOOT
IB2	x2	PH INLINE CONNECTOR
WME-1000	x2	1000MM (39.37") GREY RPVC WIRE MANAGEMENT EXTRUSION
LN-LCD2-B	x2	MEDIUM MONITOR BRACKET

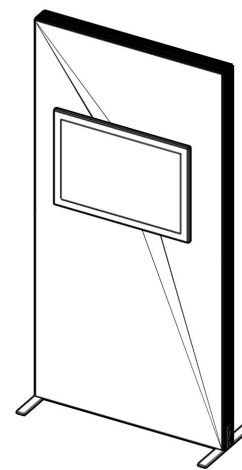
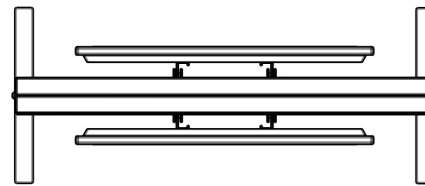
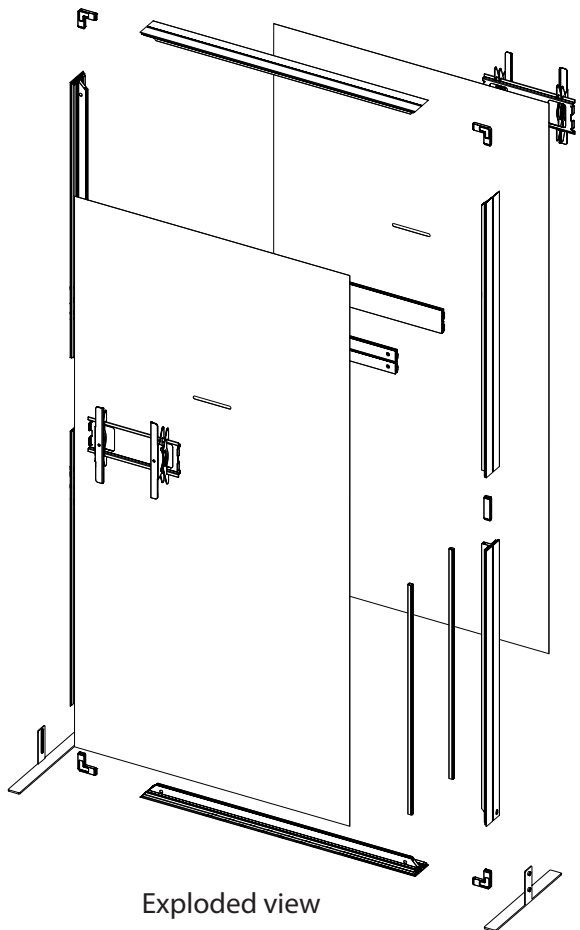

## Double Sided Step 1: Assemble Frame

Arrange pieces on the floor as shown in the diagram below. Assemble frame by locking F25s to F27s and F60. When locking be sure to turn each cam a little bit and then go back and tighten to the proper tension. Take care to turn locks only half a turn. Slide two bolts for monitor mount into channel of each VE-95 and lock to extrusion at proper height.

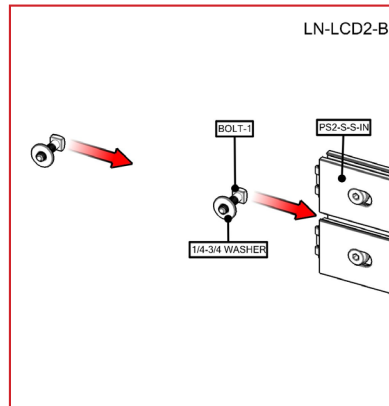
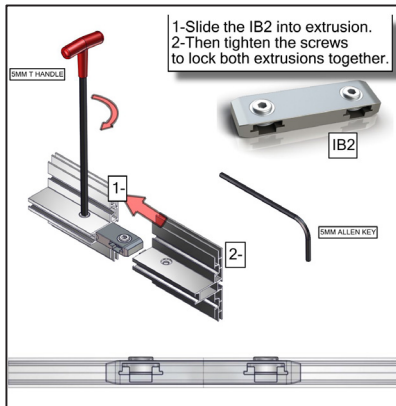

**\*Very Important!**  
Insert set of monitor bolts into each VE-95 channel before securing extrusion to F27

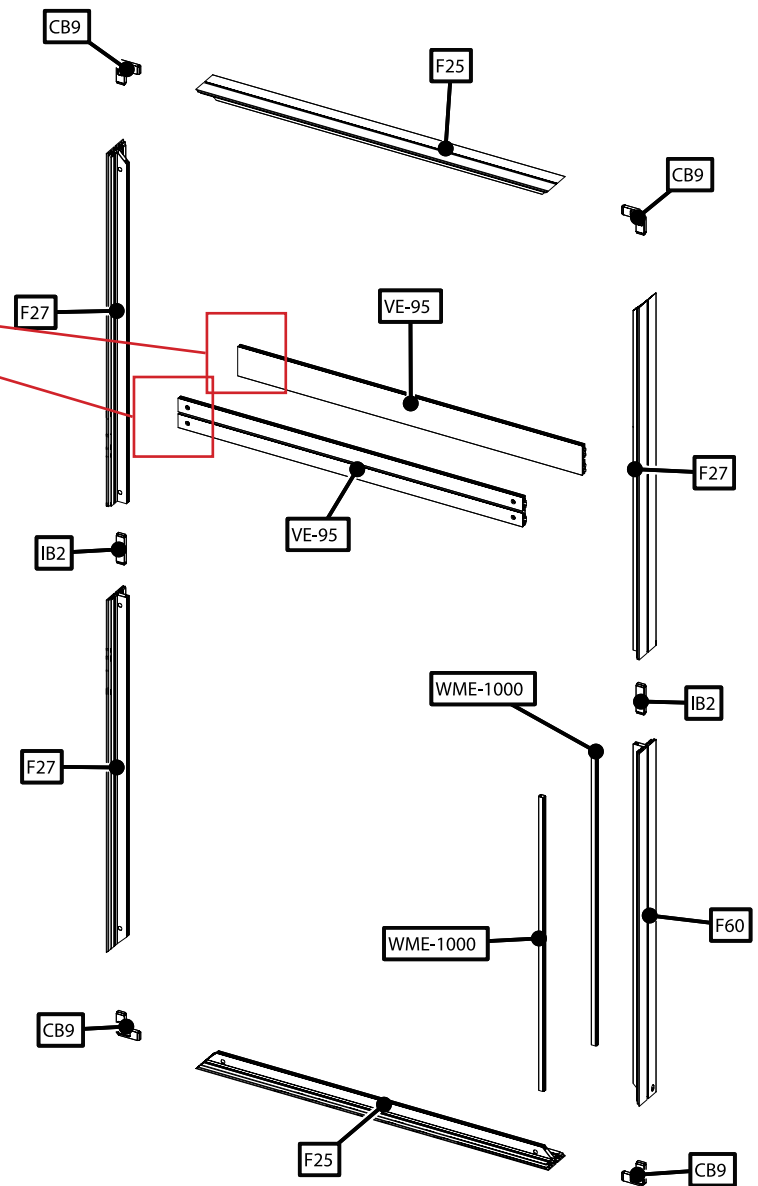
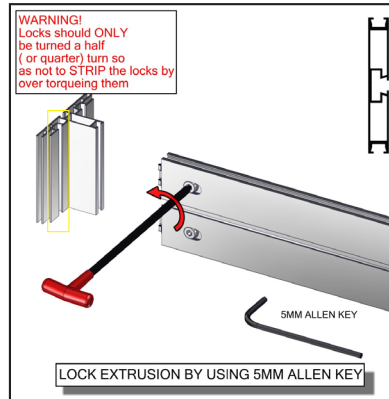
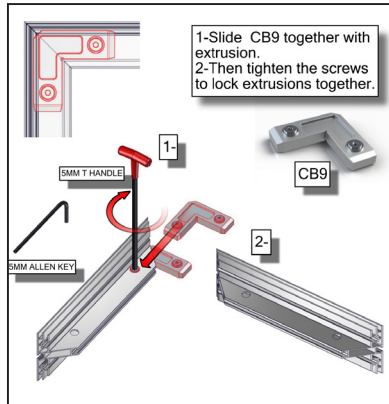



## Double Sided Step 2: Attach feet to frame & apply graphics

To adhere foot to frame, loosen thumbscrews from foot. Slide extrusion into LN-100 groove. Gently tighten the foot into place. Install graphics by pressing the FCE-2 edge of graphic into the channel of the extrusion. Make sure slit on printed fabric is near top of frame. Start in upper left corner, go across the top and then down the sides to the bottom. Assure each graphic is tightly inserted. When taking graphics off, take care to gently pull by attached pull tab.

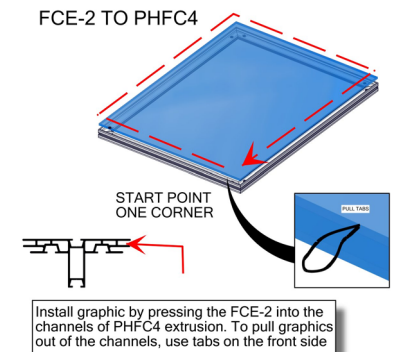
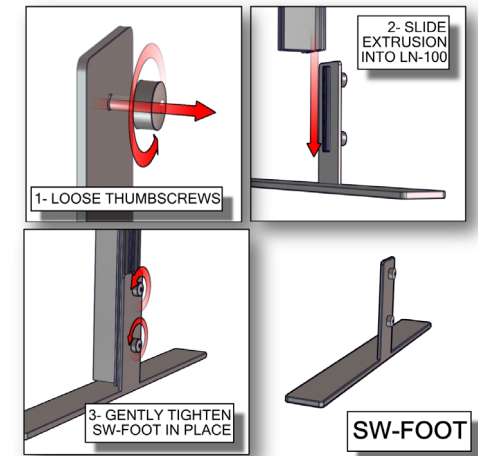
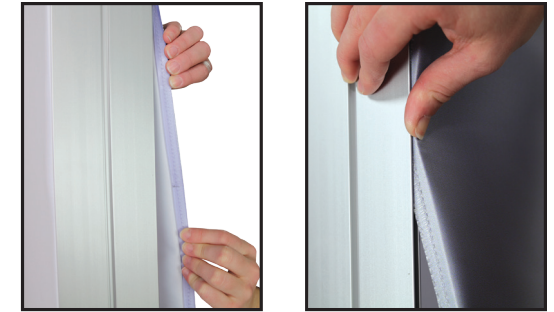
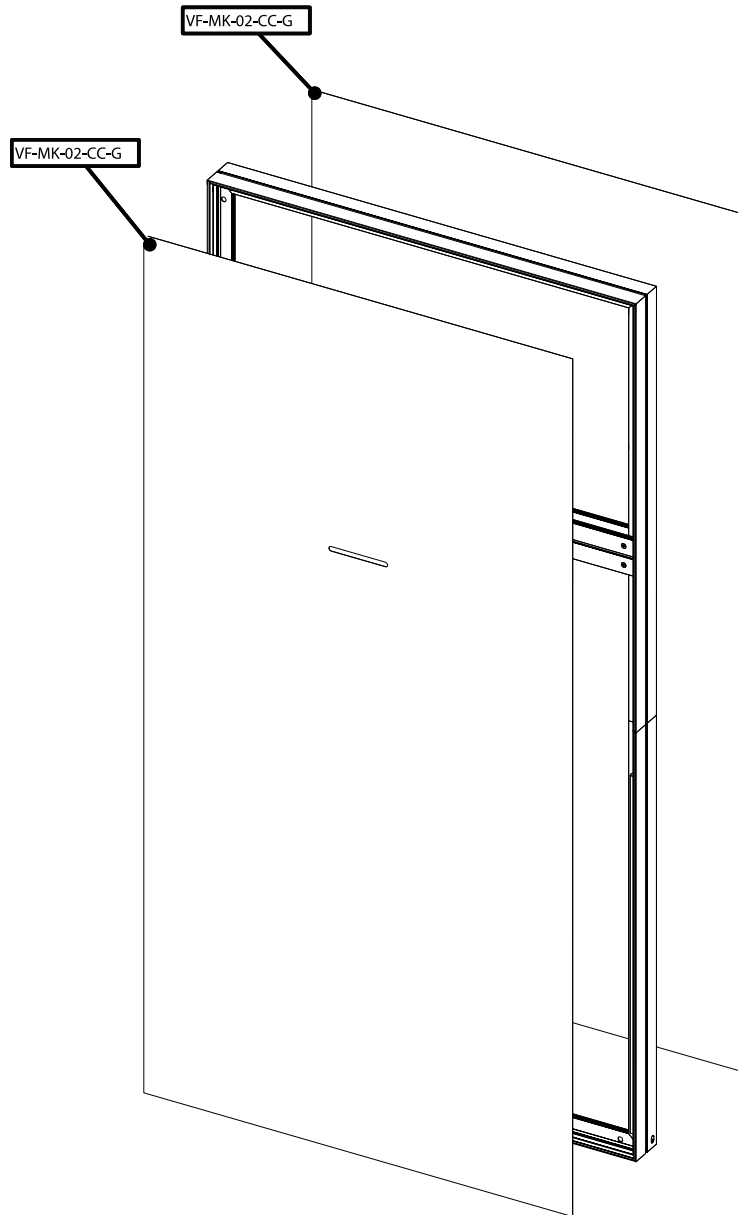

### Double Sided Step 3: Monitor Mount & Wire Management

Attach each monitor mount to bolts in VE-95 at graphic slit. Insert monitor cord into plastic wire management strip and snap on to extrusion channel. Run through hole in frame and connect to power supply.

